

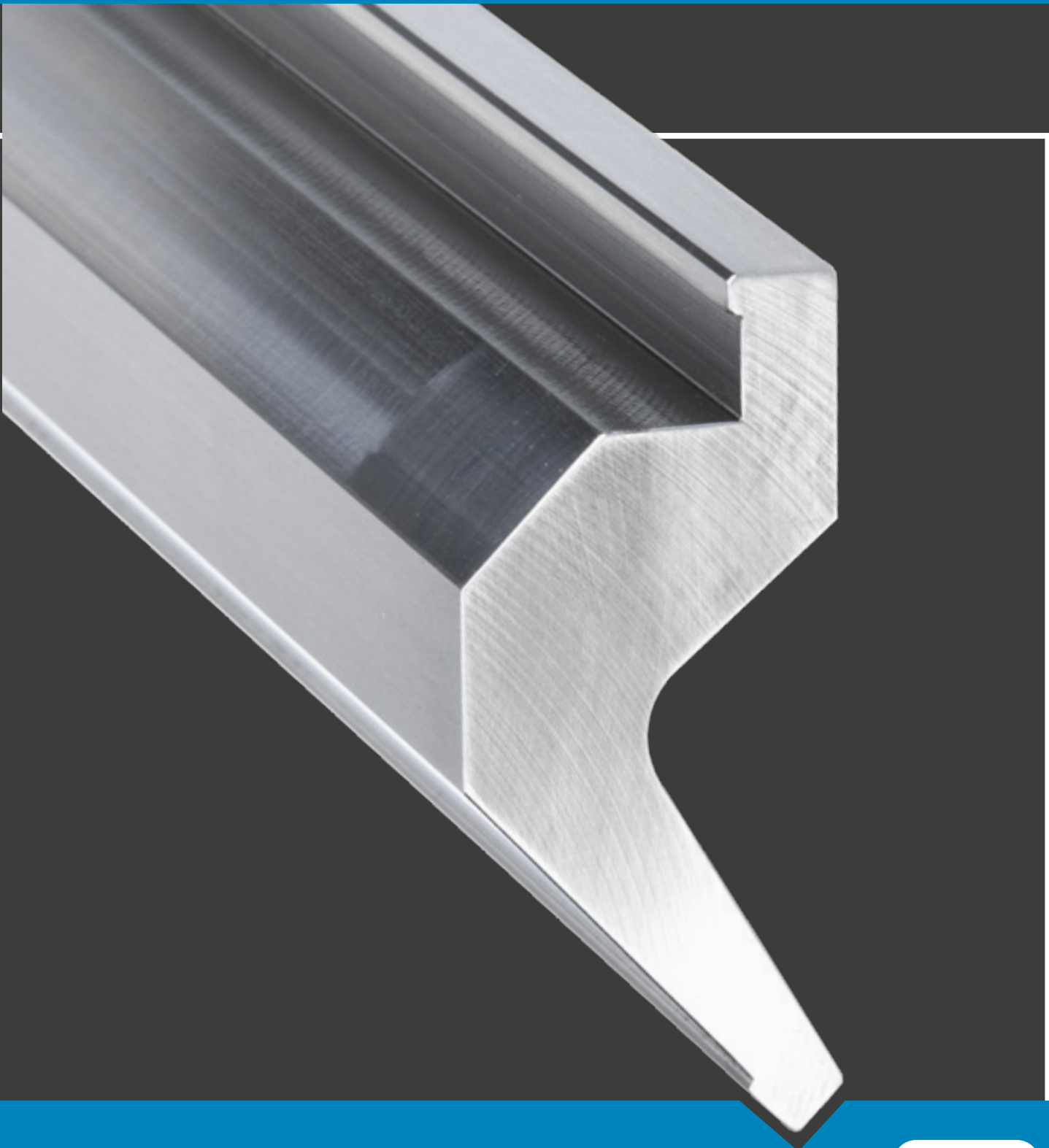

# FERRARI



**COLLY HACO**  
*Press Brake Tools*



ITA-ENG

# FERRARI COSTRUZIONI MECCANICHE

Utensili e stampi per presse piegatrici

## Azienda

**Ferrari Costruzioni Meccaniche** nasce nel 1979 a Basilicanova (PR). Da quarant'anni a fianco dei maggiori produttori di presse piegatrici, l'Azienda si distingue per ***l'efficace sinergia creatasi fra tradizione e innovazione***: investimenti tecnologici, progettazione tecnica, scelta dei materiali, controlli su ogni singolo pezzo sono aspetti fondamentali per garantire qualità delle realizzazioni e serietà del servizio offerto. Attenzione alle esigenze di ciascun cliente – anche dopo la vendita – e progettazione tecnica finalizzata alla ricerca delle migliori performance: ***i nostri punti di forza***. Seguire da vicino le evoluzioni del mercato – nazionale e internazionale – interpretandone efficacemente sviluppi ed esigenze: ***un obiettivo che da sempre perseguiamo***.

## Servizi

- Utensili e Stampi Standard
- Utensili e Stampi Speciali
- Tavole di Compensazione
- Lame da Cesovia
- Guide di Scorrimento
- Linee di Piegatura
- Fornitura Accessori

## Servizi su richiesta

- Rigeneratura Utensili Usurati
- Rigeneratura Lame da Cesovia Usurate
- Lavorazioni Meccaniche: Fresatura  
Tempra a Induzione – Rettifica

## Valore aggiunto

- Utensili e stampi costruiti con acciai certificati C45 e 42CrMo4 o secondo progetto
- ***Marchio High Quality Control*** – controlli e completa tracciabilità del prodotto
- Progettazione e lavorazione utensili di grandi dimensioni – fino a 8100 mm in un solo pezzo
- Tempra a induzione e a cuore – grande profondità di indurimento
- Rettificatrici speciali e a controllo numerico
- Utensili perfettamente intercambiabili ( $\pm 0,01\text{mm}$ )



# FERRARI COSTRUZIONI MECCANICHE

*Tools and dies for press brakes*

## Company

**Ferrari Costruzioni Meccaniche** was established in 1979 in Basilicanova (PR). 40 years alongside the major press brakes manufacturers have allowed **the company to develop a knowing synergy comprising craftsman's tradition and experience-based innovation**: investments in technology, technical design, choice of materials, tests and inspections performed on each individual item are essential elements to ensure product quality and timeliness of service. Our added value is given by the attention we pay to the needs of each customer – throughout the whole process – and by the technical design aimed at finding the best solutions and performances. Our main goal is to follow national and international market developments so as to understand customer needs better.

## Services

- Standard tools and dies
- Special tools and dies
- Compensation tables
- Shear blades
- Slide ways
- Bending lines
- Supply of accessories

## Services request

- Worn tool repair service
- Re-sharpening of worn shear blades
- Mechanical machining: milling – induction hardening – grinding

## Added value

- Tools and dies are made of certified C45 and 42CrMo4 steels or according to design
- All our tools bear the High Quality Control mark and are completely traceable
- We design and process large tools of up to 8 meters
- Induction and core hardening – considerable depth of hardening
- Special and numerical control grinding machines
- Tools are perfectly interchangeable ( $\pm 0,01$ mm accuracy)



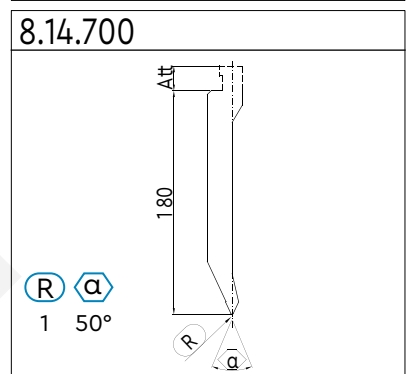
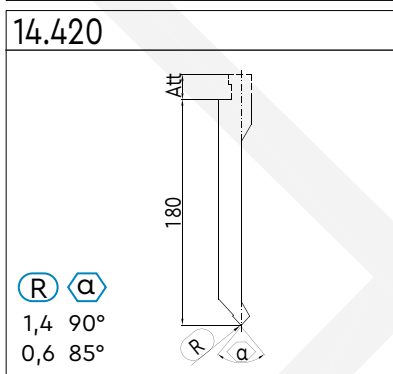
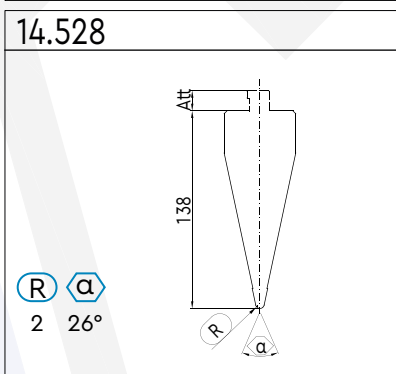
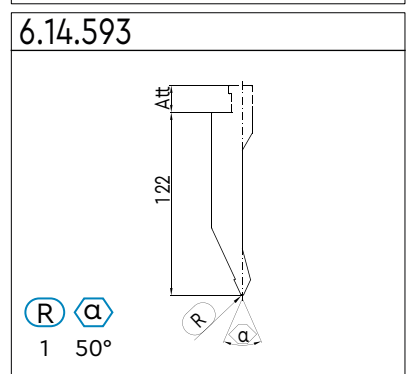
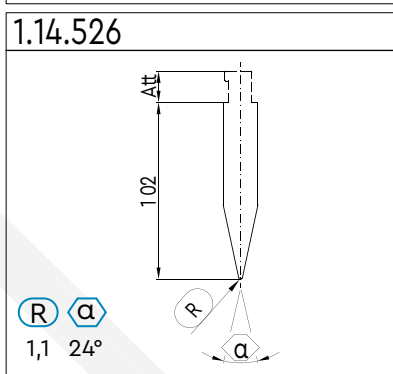
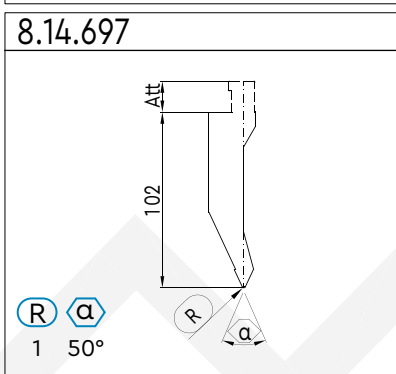
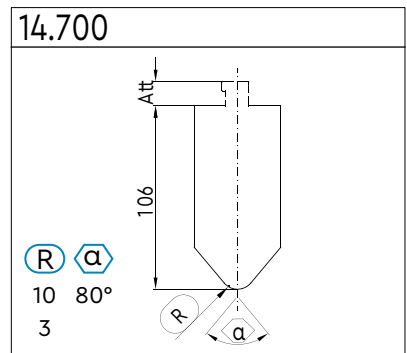
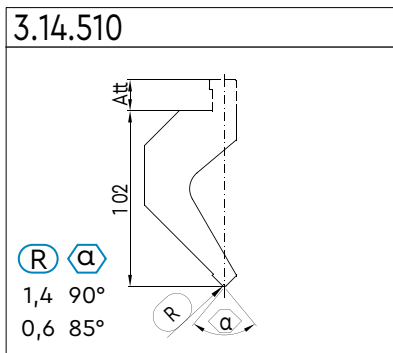
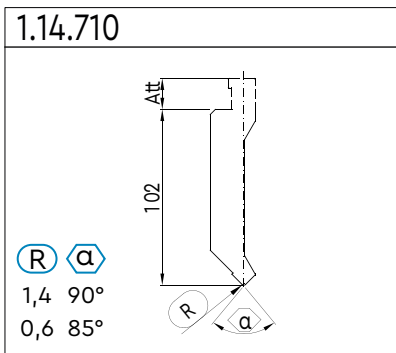
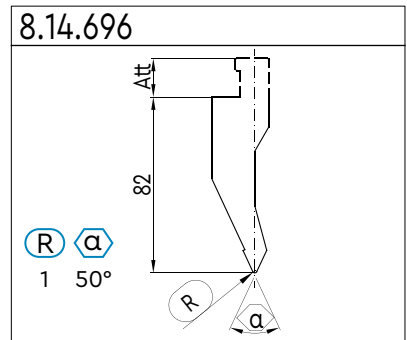
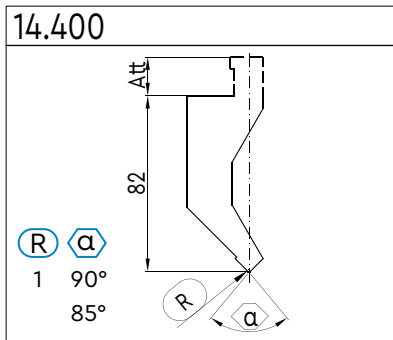
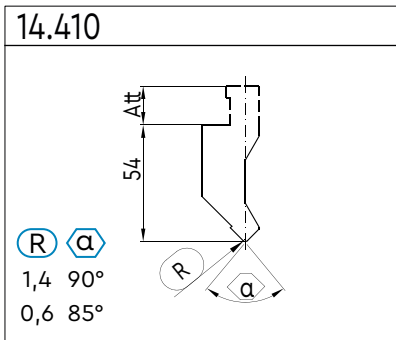
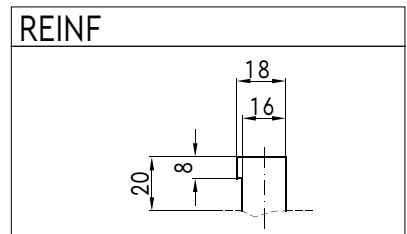
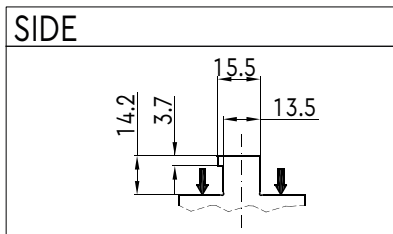
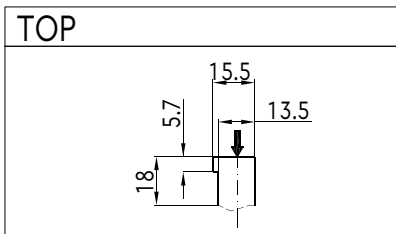

LUNGHEZZE PUNZONI COLLY/COLLY PUNCHES LENGHT

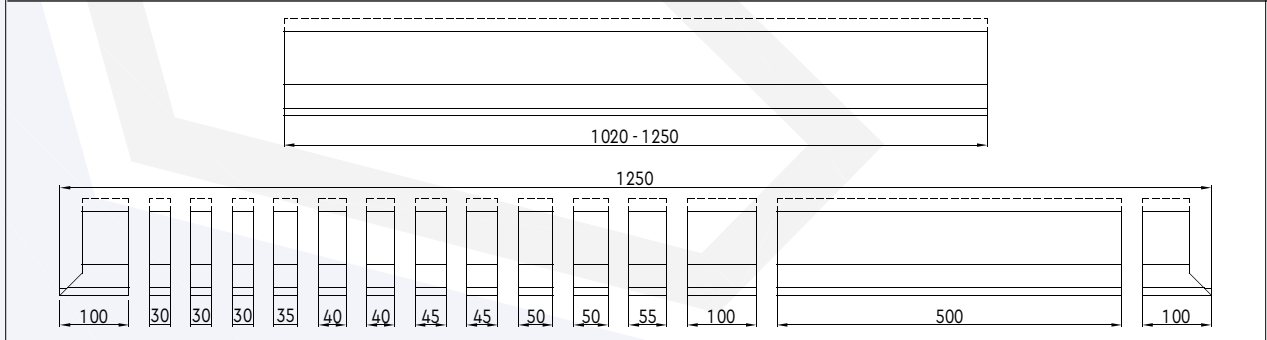

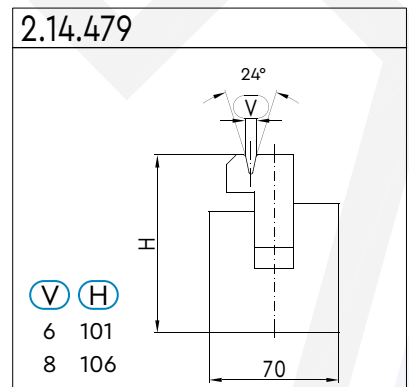
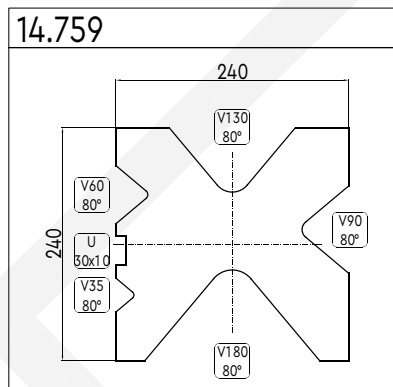
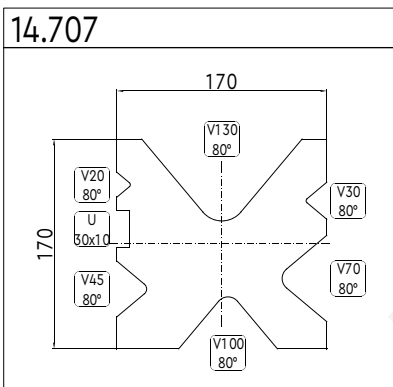
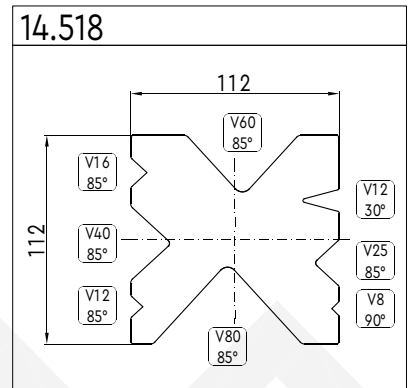
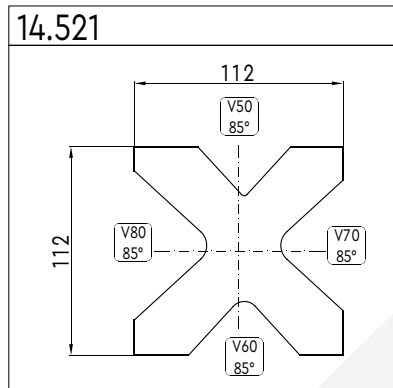
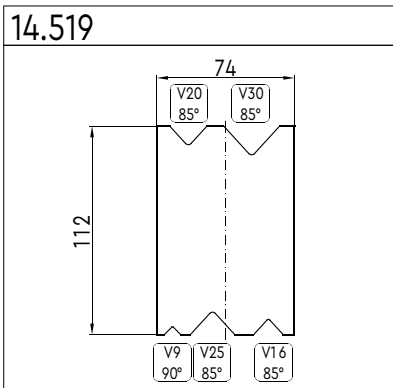
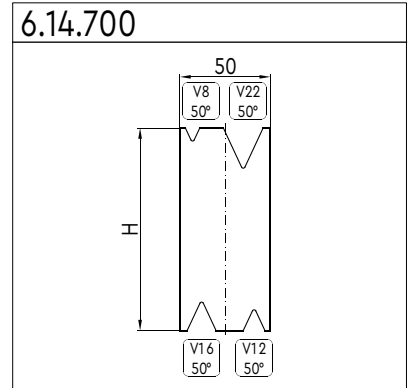
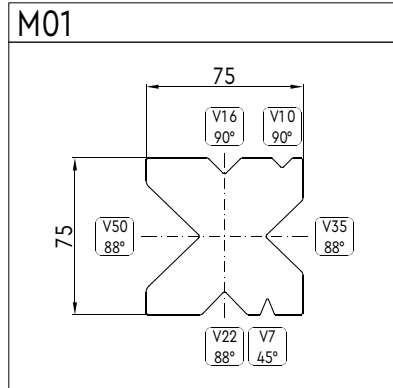
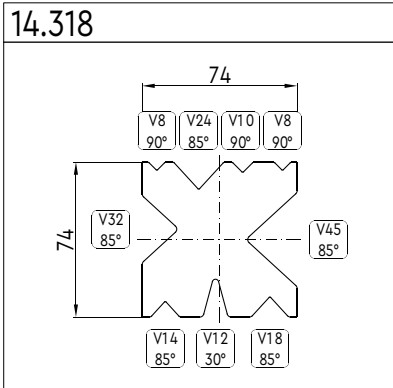
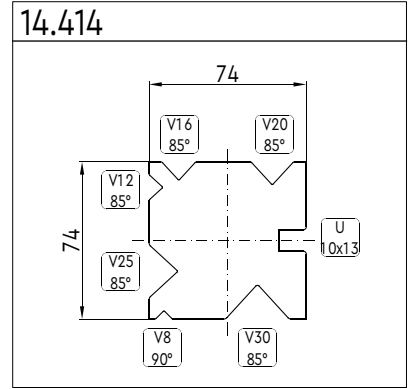
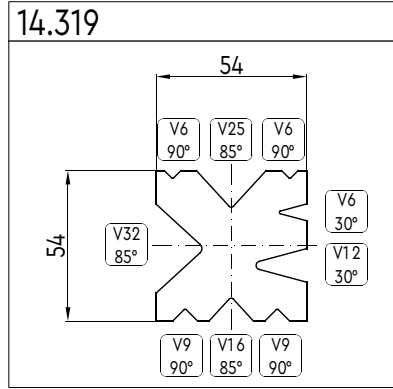
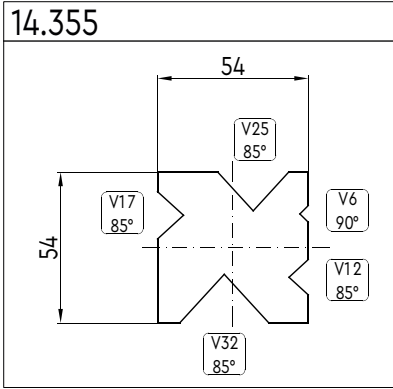

**LUNGHEZZE MATRICI COLLY/COLLY DIES LENGHT**

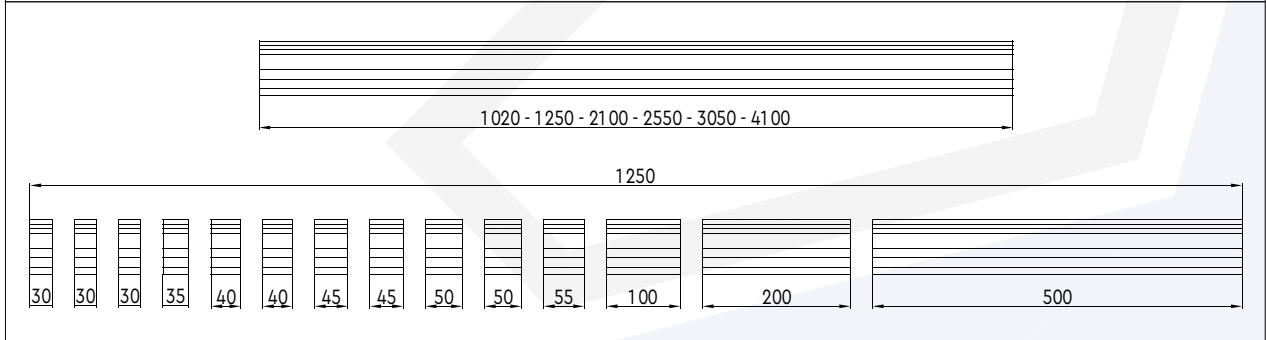

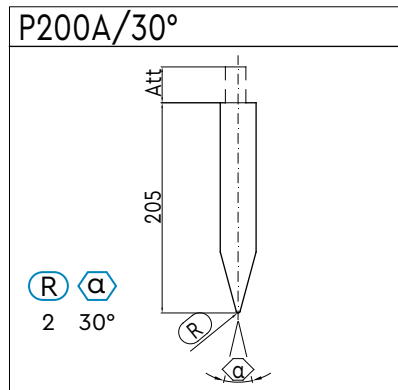
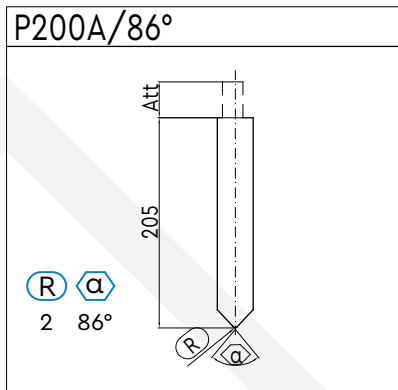
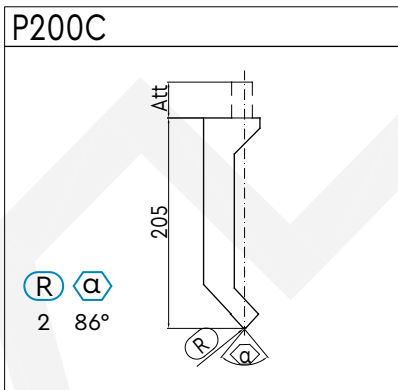
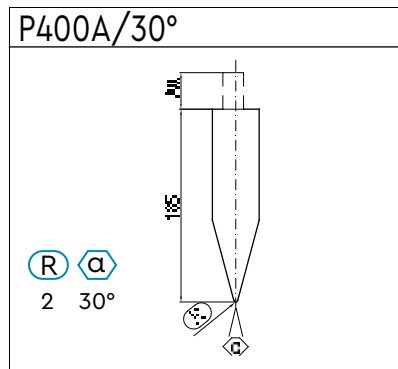
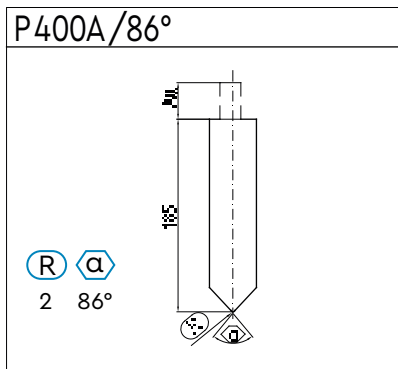
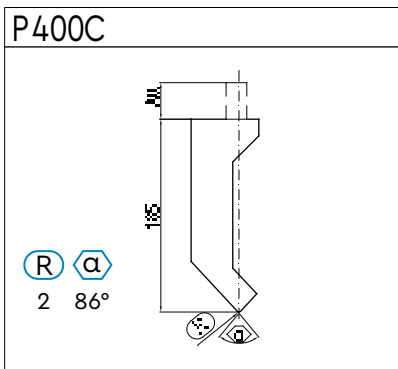
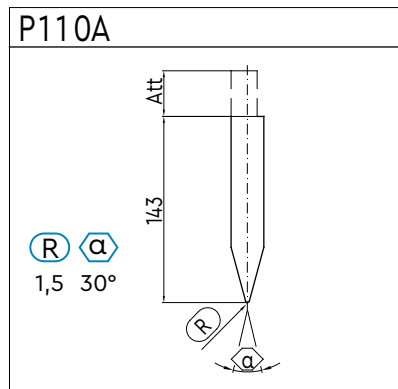
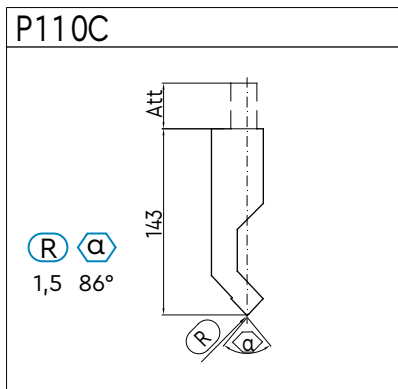
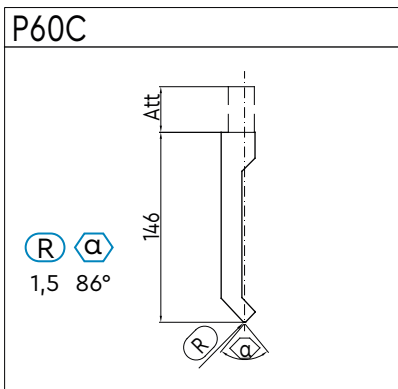
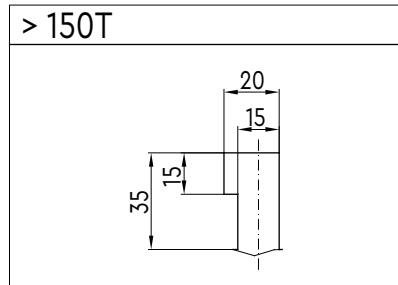
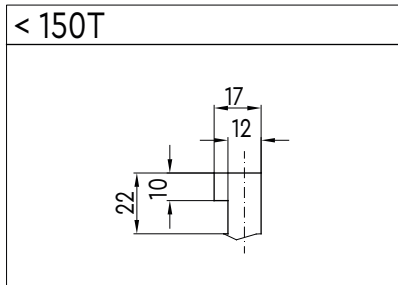
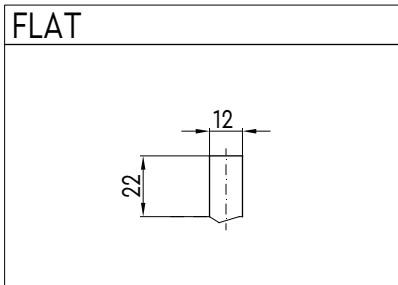

LUNGHEZZE PUNZONI HACO/HACO PUNCHES LENGHT

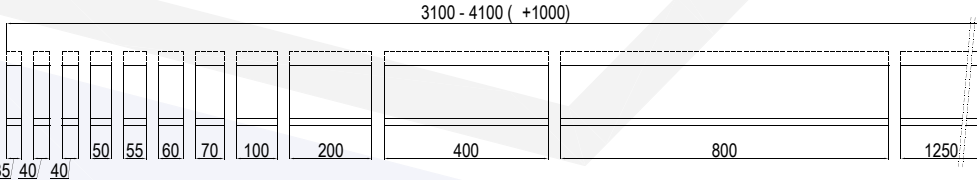
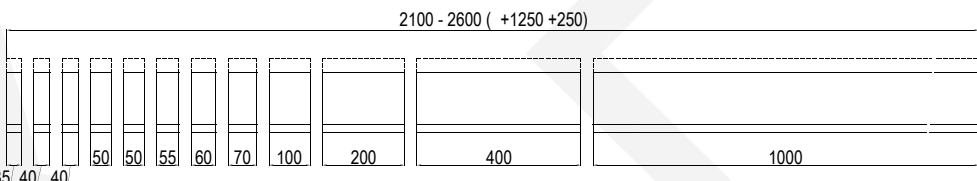
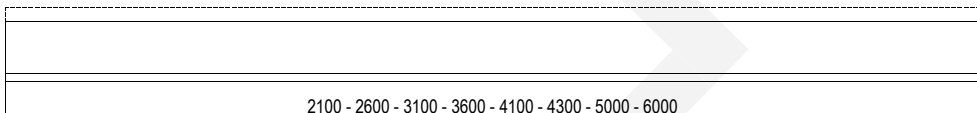

PV56

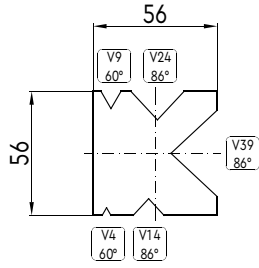

PV70

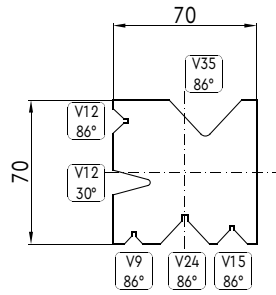

PV90

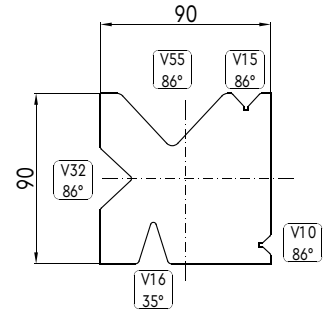

PV100

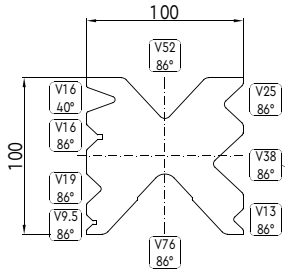

PV125

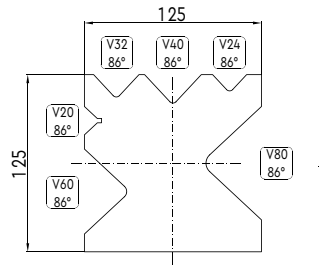

PV160

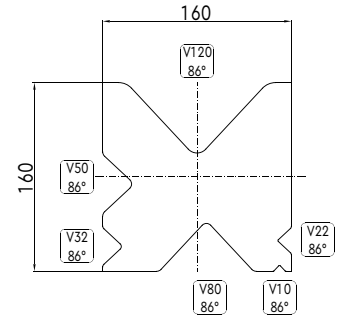

LUNGHEZZE MATRICI HACO/HACO DIES LENGHT

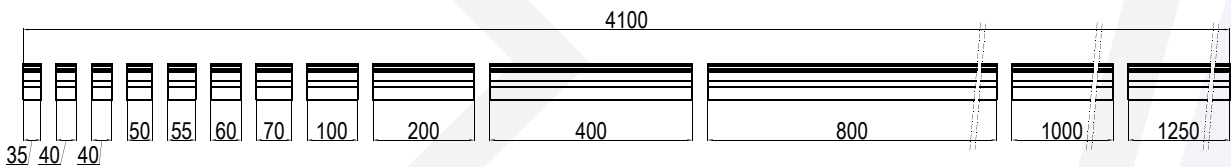
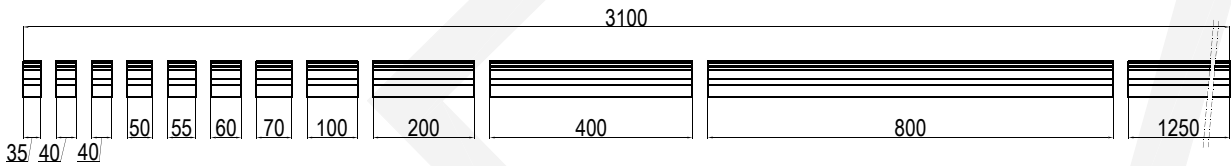
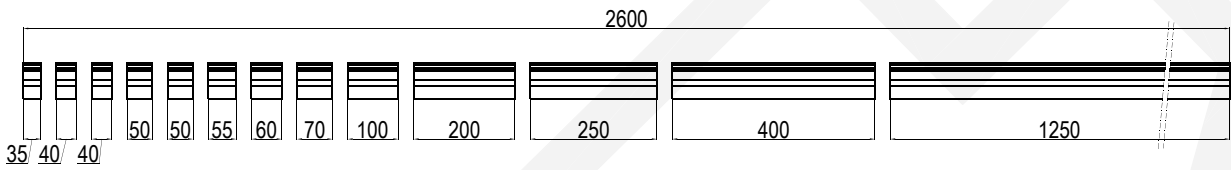
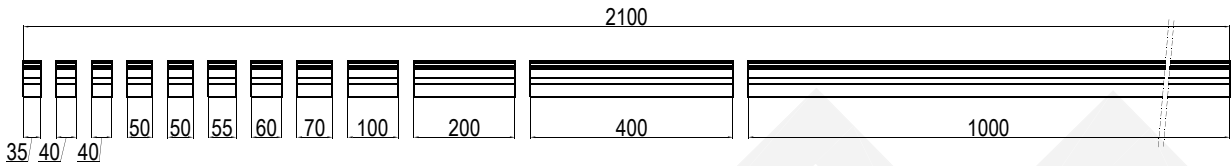
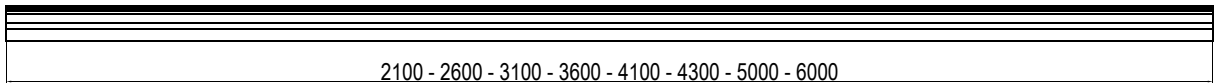

## FERRARI COSTRUZIONI MECCANICHE

**Address:** Via Ercole Calzetti 11,  
43030 Basilicanova PR – Italy

**P.Iva:** IT01817760349

**Tel.:** +39 0521 682035

**Email:** [info@ferraritools.it](mailto:info@ferraritools.it)

[www.ferraritools.it](http://www.ferraritools.it)